

## PRODUCT DATASHEET

Filtermate quarter turn ball valve. DZR body, female BSP screwed ends.

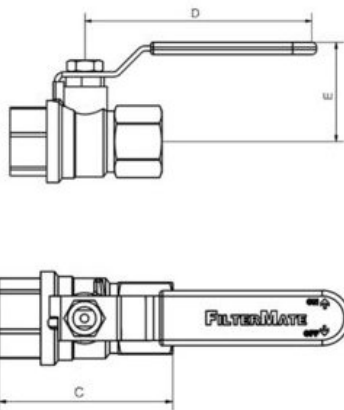

## DIMENSIONS



Part No'	Size	A	B	C	D	E	F	G	H	Weight	PN	MIN °C	MAX °C
FM5104	1/2"			62	75	39				0.20	42	-20.00	100.00
FM5106	3/4"			69	95	49				0.40	42	-20.00	100.00
FM5108	1"			84	120	61				0.70	35	-20.00	-100.00
FM5110	1 1/4"			96	120	66				1.00	35	-20.00	100.00
FM5112	1 1/2"			106	150	82				1.40	35	-20.00	100.00
FM5116	2"			127	150	89				2.20	35	-20.00	100.00

# MATERIAL

Component	Material
Ball	DZR BRASS Cw602N (CZ132)
Body	DZR BRASS Cw602N (CZ132)
Lever	PRESSED STEEL
Seat	PTFE
Stem	DZR BRASS Cw602N (CZ132)
Stem Seal	VITON

# FLOW CHARACTERISTICS

## FM51

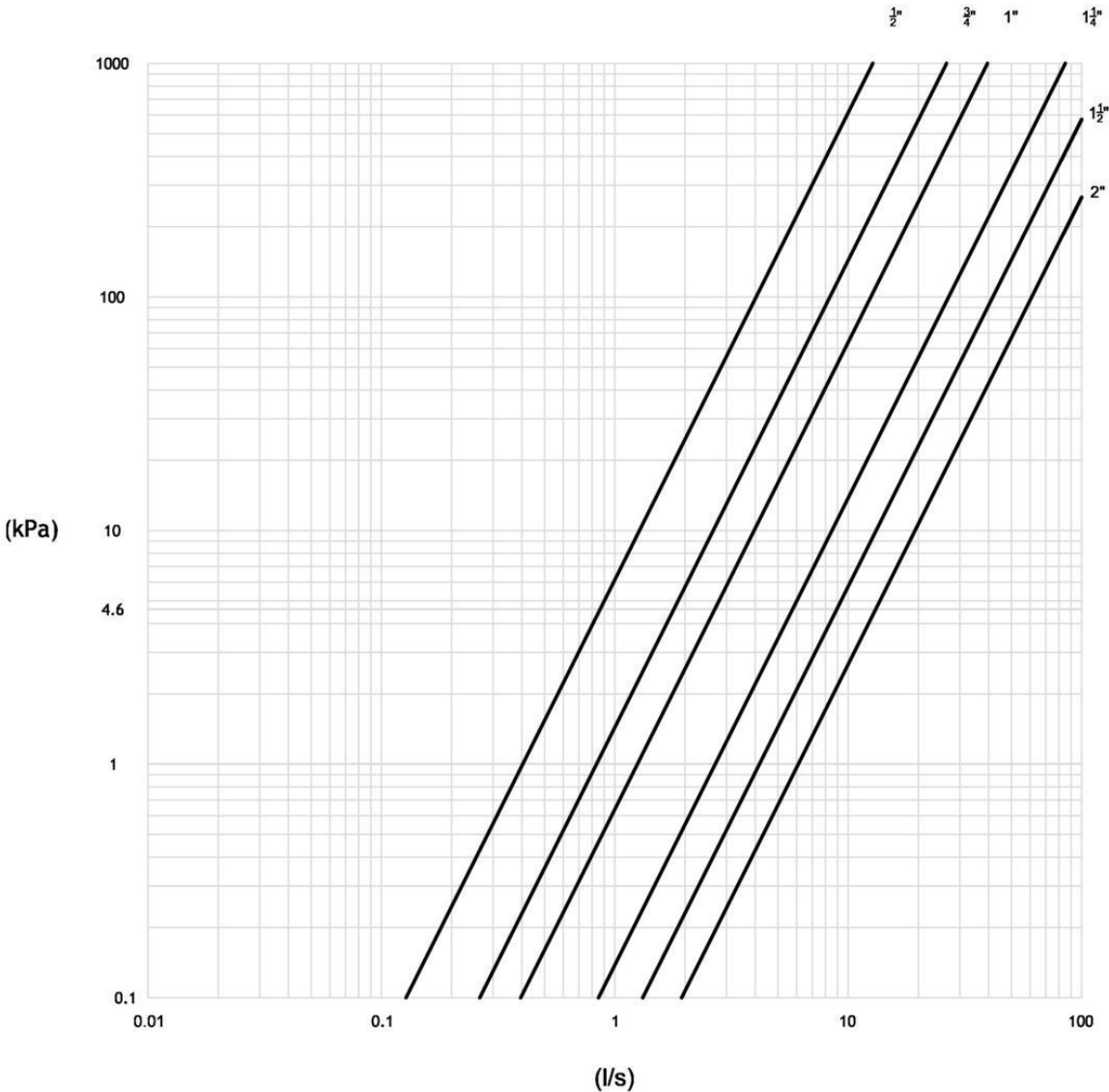

Part No'	Kv	Kvs	KV @ 30%
FM5104	14.50		
FM5106	30.00		
FM5108	45.00		
FM5110	97.00		
FM5112	150.00		
FM5116	220.00		

## SPECIFICATION TEXT

Where isolation valves DN15 - DN50 are required a Filtermate series ball valve should be installed. Quarter turn isolation valves to be manufactured from hot forged DZR body, triple sealed blow out proof stem with 2 O-Rings and virgin PTFE packing gland.

As supplied by Marflow Hydraulics Ltd

Tel: 0121 358 1555

[www.marflowhydraulics.co.uk](http://www.marflowhydraulics.co.uk)